

[www.reelschematic.com](http://www.reelschematic.com)

# Piranha

P O R T A B L E

USER'S GUIDE



## THANK YOU

Thank you for choosing Humminbird Piranha, manufactured by Techsonic Industries, for your sonar fishfinder and depthsounder. Techsonic has built its reputation by designing and manufacturing top-quality, thoroughly reliable marine equipment. Techsonic has designed your Humminbird Piranha unit to be trouble free even in the harshest marine environments.

In the unlikely event that your Humminbird Piranha product does require repairs, Techsonic offers an exclusive Service Guarantee - free of charge during the first year after purchase, and available at a reasonable rate after the one-year period. Complete details are included at the end of this manual.

We encourage you to read this operations manual carefully in order to get full benefit from all the features and uses of your Humminbird Piranha product.

***WARNING! This device should not be used as a navigational aid to prevent collision, grounding, boat damage, or personal injury. When the boat is moving, water depth may change too quickly to allow time for you to react. Always operate the boat at very slow speeds if you suspect shallow water or submerged objects.***

**WARNING:** Disassembly and repair of this electronic unit should only be performed by authorized service personal. Any modification of the serial number or attempt to repair the original equipment or accessories by unauthorized individuals will void the warranty. Handling and/or opening this unit may result in exposure to lead, in the form of solder.

**Warning:** This product contains lead, a chemical known to the State of California to cause cancer and birth defects and other reproductive harm.

## TABLE OF CONTENTS

Section 1: CASE ASSEMBLY	2
Introduction	2
Portable Case Assembly	2
Attaching the Control Head	3
Assembling the Transducer Mount	3
Attaching the Transducer Cable	4
Installing the Batteries	5
Section 2: MOUNTING	5
Mounting the Transducer	5
Mounting the Case	6
Surface Mount	6
Nylon Web Strap	7
Removing the Case after Use	7
Section 3: MAINTENANCE AND WARRANTY	8
Maintenance	8
Replacing the Battery Power Cable	8
Warranty	9
Service Policy	10
Section 4: SPECIFICATIONS	11

## CASE ASSEMBLY

### INTRODUCTION / ATTACHING THE CONTROL HEAD

#### Introduction to CASE ASSEMBLY

The Piranha Portable is available in several different configurations. You may have purchased the portable case complete with a Piranha unit ready for operation.

A Piranha control head you already own may also be used with the portable case.

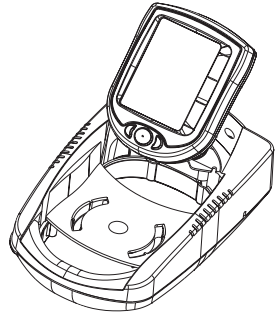

The Piranha Portable contains the portable case, a removable power cable, transducer with 15 feet of cable, the suction cup transducer mounting kit, and various connecting hardware.

This manual serves for all applications, so there may be some minor differences between the manual and the actual hardware included, depending on the configuration you purchased.

Piranha Portables are sold with the Piranha 1, 2, 2x, 4, 4x Control heads. The PTC Portable Piranha kit is adaptable to all Piranha fishfinders.

#### PIRANHA PORTABLE CASE ASSEMBLY

##### Case Assembly Overview

In the following step-by-step procedures the following portable case assembly tasks are described, and must be performed in order:

1. Attaching the control head
2. Assembling the transducer mount
3. Attaching the transducer cable
4. Installing the batteries.

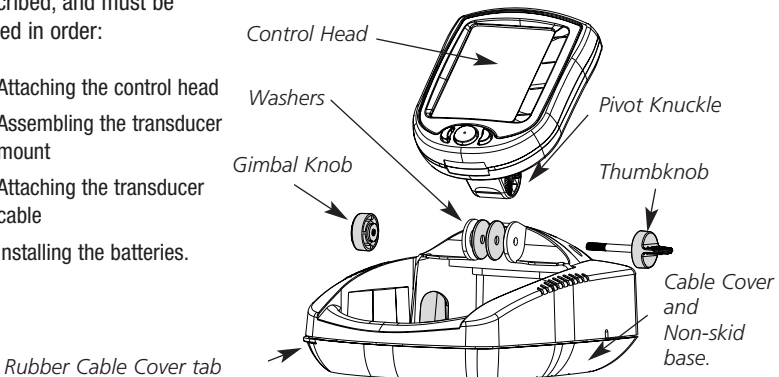

## CASE ASSEMBLY

### ATTACHING THE CONTROL HEAD / ASSEMBLING THE TRANSDUCER MOUNT

#### Attaching the Control Head

1. Remove the pivot bolt, gimbal knob, and rubber washers from the hardware bags.
2. Place the rubber washers between the control head's pivot knuckle and the arms from the portable case. Make sure that the control head screen is facing the case.
3. Slide the pivot bolt through the left side and screw the gimbal knob onto it using only 2-3 turns. The gimbal knob has two alignment pins that will seat into holes in the case arm holding the Piranha control head. Make sure these pins are seated and then tighten the assembly to a snug tension.

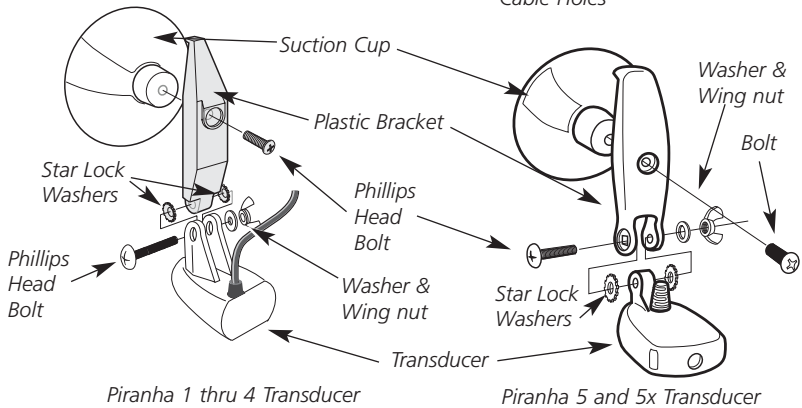
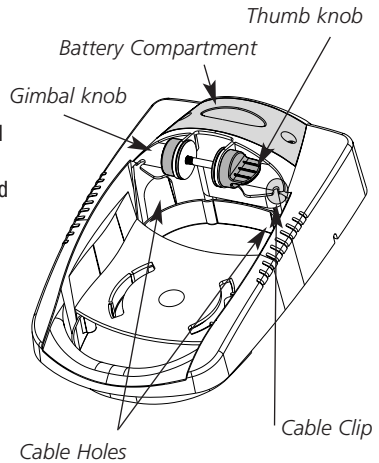

#### Assembling the Transducer Mount

**Note: Depending on your transducer type, you will use only one of the two mounting brackets included (see illustrations).**

1. With a #2 Phillips screwdriver, attach the suction cup to the mounting bracket using the 1/4-20 x 3/4" machine screw. Hand tighten only; do not use power tools.
2. Connect the transducer body to the mounting arm using a #2 Phillips screwdriver and the hardware shown. Hand tighten only; do not use power tools.

## CASE ASSEMBLY

### ATTACHING THE TRANSDUCER CABLE

#### Attaching the Transducer Cable

1. Flip open the rubber cable retaining cover on the back of the case by pulling on the tab located at the upper left corner.
2. Thread the end of the transducer cable through the transducer cable hole which is located on the back of the case (see illustration).
3. Plug the transducer cable into the back of the control head.
4. Turn the case so that you are looking at the front, and make sure there is enough slack in the transducer cable, then push it into the transducer cable clip on the left (see illustration).
5. Wind the transducer cable around the cable channel.
6. When finished winding, clip the cable on one of the two indentions located on either side of the case.
7. Push down on the cable cover to conceal the cable.
8. Attach the suction cup transducer assembly to the back of the case by pinching the suction cup on both sides and allowing it to snap into the universal mount. (This universal mount also acts as a surface mount attachment. See the Surface Mount section for more information.)

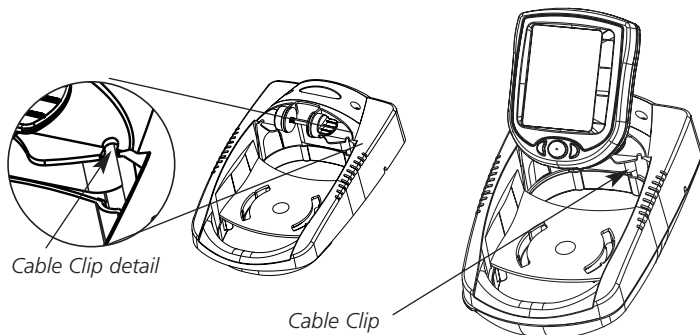
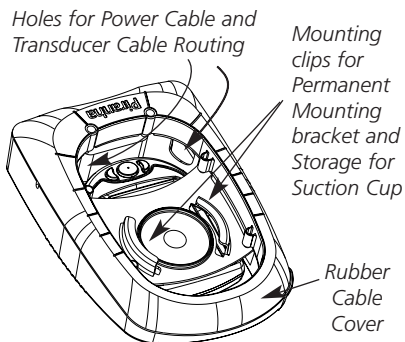

## CASE ASSEMBLY

### INSTALLING THE BATTERIES / INTRODUCTION TO MOUNTING

#### Installing the Batteries

1. With a #2 Phillips screwdriver, remove both screws located on either side of the battery door.
2. Insert the 8 AA batteries (not included) into the case as shown on the diagram inside the battery compartment.

**Note: It is recommended that only high quality alkaline batteries be used.**

3. Before reattaching the battery door, make sure the silicon gasket is still in place. It should be just above with the plastic, and completely in the gasket channel. Make sure that the gasket is clean of debris.
4. Reattach the battery door to the case using a #2 Phillips screwdriver. Partially insert one screw and then the other. Fully seat the screws.  
Hand tighten only; do not use power tools.
5. Under normal use you should expect the life of the batteries to last 25 hours with the LCD backlights on, to 60 hours with the backlights off.

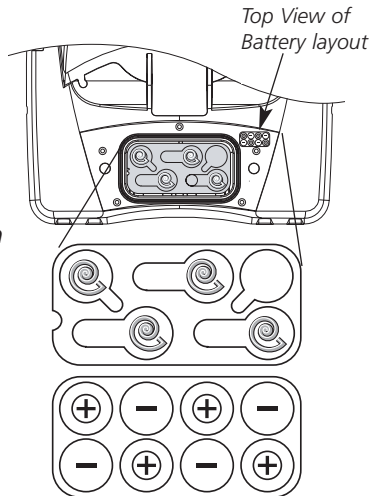

*Enlarged view of battery layout  
Polarity shows top of battery as  
viewed with the battery installed.*

#### INTRODUCTION TO MOUNTING

Once your Piranha Portable is fully assembled, (see the Piranha Portable Case Assembly section for more information) it takes just a few easy steps before you are ready to fish, namely:

1. Mounting the Transducer
2. Mounting the Case.

#### Mounting the Transducer

1. Detach the transducer suction cup mount from the back of the case.
2. Unwind the desired amount of cable needed for the fishing platform and then clip cable on one of the two indentions located on either side.
3. Attach the suction cup to the back of the hull next to the motor. Make sure to keep the transducer at least 20 inches away from the motor.

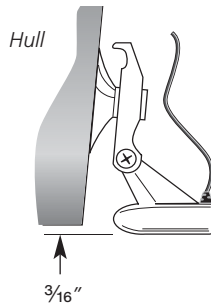

## MOUNTING THE CASE

### MOUNTING THE CASE / SURFACE MOUNT

4. When using the suction cup transducer on a moving boat, it is best to secure the transducer cable in case of accidental release. A loose transducer cable can cause damage to itself, your boat, or become entangled in the propeller. Attach the tie down strap to the transducer cable and loop the cable around an immovable object such as a rail or fitting as shown in the illustration.
5. If desired, mount the case (see Mounting the Case section for more information).
6. Rotate the control head up, power on, and fish (for information on how to use the control head see your Piranha Operations manual).

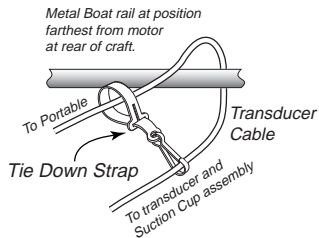

### MOUNTING THE CASE

Since it has a large rubber footprint, the Piranha Portable case grips to almost any surface. If a more secure attachment is desired, however, there are a couple of different options to choose from:

1. Surface mount (not included)
2. Nylon web strap (not included).

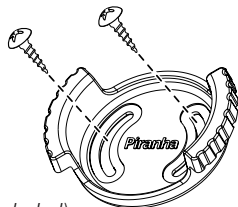

### Surface Mount

*Surface Mount, (not included)*

The Piranha Portable surface mount is an easy to install mount that allows for quick and secure attachment to many different surfaces.

1. Place the surface mount on the desired surface and make sure there is enough room to rotate the case 180 degrees.
2. Put a mark in each curved slot located on the surface mount.
3. Remove the mount and drill two  $\frac{1}{8}$ " (3.2mm) pilot holes.
4. Using a #2 Phillips screwdriver, attach the two #8 screws and black washers provided in the hardware bags. Hand tighten only; do not use power tools.
5. For best results have the "Piranha" text on the surface mount face you right side up and horizontal, reading from left to right, as shown in the illustration. This will line up the control head.
6. Align the universal mount on the back of the Piranha Portable case with the surface mount by turning the portable case 90 degrees.



## MOUNTING THE CASE

### NYLON WEB STRAP / REMOVING THE CASE AFTER USE

7. Press the center section and then twist the Piranha Portable case until it is facing you. Six clicks produces maximum clamping and aligns the control head.
8. For fine-tuning, remove the Piranha Portable case and loosen the two screws. Rotate the surface mount and retighten the screws.

#### **Nylon Web Strap (not included)**

There are multiple ways in which to strap your Piranha Portable to your fishing platform:

1. Friction grooves, located on the left and the right of the Piranha Portable case, are specially designed to grip a standard 1/2 to 2 inch nylon web strap. With the control head up you can make use of the friction grooves by wrapping the nylon web strap around the case.
2. Other ways of strapping that make use of a 1/2-inch nylon web strap that is positioned across the suction cup retainer bridge, (see illustration above). This is useful when strapping to a seat or tube.

*Cross strap for Kayaks and similar craft.*

*Through strap for boat seats or tubes*

*Top of permanent mounting area, (press slightly to engage Permanent Mounting Clip.*

*Surface mounting using straps*

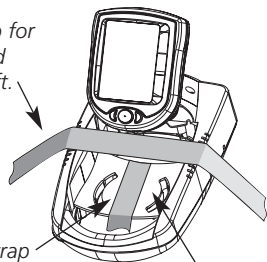

#### **REMOVING THE CASE AFTER USE**

1. With the boat engine off, loosen all cable retainers/clips holding the transducer.
2. Remove the case from the surface mount.
3. Remove the transducer from the surface where it has been mounted.
4. Turn the case over, flip open the rubber cable retainer by pulling on the tab located at the upper left corner, and wrap the cable back into the cable run, then push the cable under the outer cable clip.
5. If you will not be using the unit again in the near future, remove the batteries to prevent corrosion, and store.

*Control Head*

*Power Cable*

*Transducer Cable*

*Thumbknob*

*Pivot Knuckle*

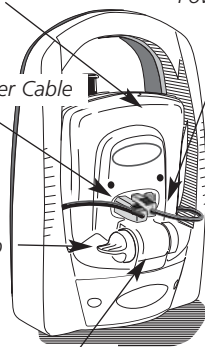

*Piranha Portable Ready to travel*

## MAINTENANCE AND WARRANTY

### MAINTENANCE / REPLACING THE BATTERY POWER CABLE

#### MAINTENANCE

Your Humminbird Portable fishfinder is designed to provide years of trouble-free operation with virtually no maintenance. Follow the simple procedures below to ensure that your Humminbird Portable continues to deliver top performance.

If you are storing the Portable case for an extended period of time, it is best to remove the batteries from the case in case of leakage.

If the Portable case comes into contact with salt spray, simply wipe the affected surfaces with a cloth dampened in fresh water.

Never leave your Humminbird Portable unit in a closed car or trunk - the extremely high temperatures generated in hot weather can damage the electronics. Repairs should be performed only by authorized Humminbird technicians.

#### Replacing the Battery Power Cable

**Note: You will not have to install the battery power cable before first use, but may need to replace it should it become corroded after prolonged usage in a marine environment.**

1. Flip open the rubber cable cover/retainer on the back of the case by pulling on the tab located at the upper left corner.
2. Make sure the transducer cable is totally removed from the cable channel, detach the power cable from the control head and pull the power cable through the power cable hole.
3. Using a 1/4" hex driver, unscrew the battery cable ends from the positive and negative studs.
4. Clean the studs if they are corroded.
5. To install a new power cable, place the red wire on the positive stud and the black wire on the negative stud.

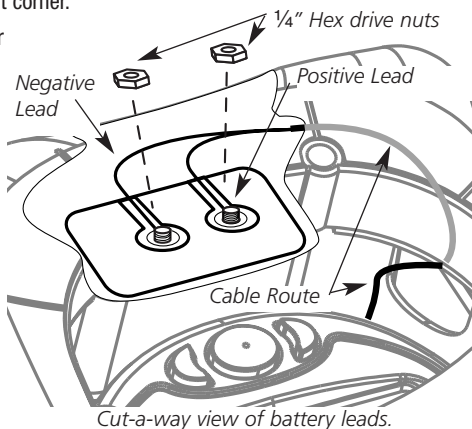

## MAINTENANCE AND WARRANTY

### TECHSONIC INDUSTRIES' 1 - YEAR LIMITED WARRANTY

6. Hand tighten both with a ¼" hex driver. (Do not use power tools.)
7. Thread the other end of the power cable through the power cable hole.
8. Make sure there is enough slack in the wire, then push it under the power cable clip.
9. Plug the power cable into the back of the control head.
10. Push down on the cable retainer to conceal the cable.

#### TECHSONIC INDUSTRIES' 1-YEAR LIMITED WARRANTY

We warrant to the original retail purchaser that Techsonic Industries products have been manufactured free from defects in materials and workmanship. This warranty is effective for one year from the date of original retail purchase, excepting that where Techsonic Industries products are used commercially or in any rental or other income producing activity; then this warranty is limited to ninety days from the date of original purchase for mechanical and electrical products (or one year from the date of original purchase for hydraulic products).

We will provide replacement product without charge for any Techsonic Industries product not covered by this warranty, which is returned (freight prepaid) within the warranty period to the dealer from whom such products were purchased, or to us at the appropriate address. In any such case, Techsonic Industries products found to be defective and covered by this warranty will be replaced or repaired at Techsonic Industries' option, and returned to the customer.

Techsonic Industries' sole responsibility under this warranty is limited to the repair or replacement of product which is, in Techsonic Industries' opinion, defective. Techsonic Industries is not responsible for charges connected with the removal of such product or reinstallation of replacement or repaired parts.

We will have no obligations under this warranty for any product which:

- has been improperly installed;
- has been used in an installation other than as recommended in our installation or operation instructions or specifications;
- has failed or has been damaged due to an accident or abnormal operation including racing, misuse or alterations outside our factory;
- has been repaired or modified by entities other than Techsonic Industries;
- has been used on an engine/boat combination where the engine horsepower exceeds the rating established by the boat manufacturer;
- has been used with other product(s) which, in Techsonic Industries' opinion, are incompatible with the Techsonic Industries product.

THIS WARRANTY IS EXPRESSLY IN LIEU OF ANY OTHER WARRANTIES, OBLIGATIONS OR LIABILITIES ON THE PART OF Techsonic Industries AND WILL BE THE CUSTOMER'S EXCLUSIVE REMEDY EXCEPT FOR ANY APPLICABLE IMPLIED WARRANTIES UNDER STATE LAW WHICH ARE HEREBY LIMITED IN DURATION TO ONE YEAR FROM THE DATE OF ORIGINAL PURCHASE. IN NO EVENT WILL Techsonic Industries BE LIABLE FOR ANY INCIDENTAL OR CONSEQUENTIAL DAMAGES FOR BREACH OF ANY EXPRESS OR IMPLIED WARRANTY RELATING TO THE PRODUCTS.

Some states do not allow limitations on an implied warranty, or the exclusion of incidental or consequential damages, so the above exclusions may not apply to you. You may also have other rights which vary from state to state.

Techsonic Industries products returned under this warranty must be tagged with the customer's name, street address, and phone number to ensure proper handling, and returned freight prepaid to the selling dealer or to the appropriate Techsonic Industries manufacturing facility.

#### International Models

A separate Warranty is provided by international distributors for the **INTERNATIONAL MODELS**. This warranty is included by your local distributor and this distributor maintains local service for your unit. Warranties are only valid in the area of intended distribution.

## MAINTENANCE AND WARRANTY

### SERVICE POLICY/ CUSTOMER RESOURCE CENTER

#### **SERVICE POLICY**

This Service Policy is valid in the United States only. This applies to Humminbird units returned to our factory in Eufaula, Alabama, and is subject to change without notice.

All repair work is performed by factory-trained technicians to meet exacting factory specifications. Factory serviced units go through the same rigorous testing and quality control inspection as new production units.

Even though you'll probably never need to take advantage of our incredible service guarantee, it's good to know that we back our units this well. We do it because you deserve the best. We will make every effort to repair your unit within three working days from the receipt of your unit. This does not include shipping time to and from our factory. Units received on Friday are usually shipped by Wednesday, units received Monday are usually shipped by Thursday, etc.

We reserve the right to deem any product unserviceable when replacement parts are no longer reasonably available or impossible to obtain.

After the original warranty period, a standard flat rate service charge will be assessed for each repair (physical damage and missing parts are not included). Please call our Customer Support Department to verify the service charge for your unit.

If charges are not prepaid, the unit will be returned C.O.D. If you are experiencing problems related to bottom or depth readings, please send your transducer along with your unit when sending for repair.

#### **CUSTOMER RESOURCE CENTER**

If you have any questions, call our Humminbird Customer Resource Center Hotline:

**1-334-687-0503**

Throughout the U.S. and Canada, hours are Monday-Friday, 8:15 a.m. to 4:45 p.m. Central time.

Or visit our web site: [www.humminbird.com](http://www.humminbird.com) for Product Support and troubleshooting guides.

**Humminbird  
Service Department  
108 Maple Lane  
Eufaula, AL 36027**

## SPECIFICATIONS

### ***SPECCIFICATIONS***

Portable Case . . . . .9¾" H x 6¼" W x 5" D  
. . . . .248mm H x 159mm W x 127mm D  
Power Requirement . . . . .Eight AA 1.5 volt alkaline batteries (*Not included*)  
Mounting . . . . .Versatile options, from quick disconnect to web strap.

